

ARDEN P.U.D. POD A WEST AND POD B WEST

BEING A REPLAT OF A PORTION OF TRACT "FD", ARDEN PLAT 1, AS RECORDED IN PLAT BOOK 122, PAGES 32 THROUGH 51, PUBLIC RECORDS OF PALM BEACH COUNTY, FLORIDA, AND LYING IN SECTIONS, 28 AND 33, TOWNSHIP 43 SOUTH, RANGE 40 EAST, PALM BEACH COUNTY, FLORIDA. SHEET 13 OF 13

148

COUNTY OF PALM BEACH)
STATE OF FLORIDA) SS
THIS PLAT WAS FILED FOR RECORD AT)
M. THIS) DAY OF)
2016, AND DULY)
RECORDED IN PLAT BOOK NO.)
ON PAGE) THRU)
SHARON R. BOCK,)
CLERK AND COMPTROLLER)
BY:) D.C.

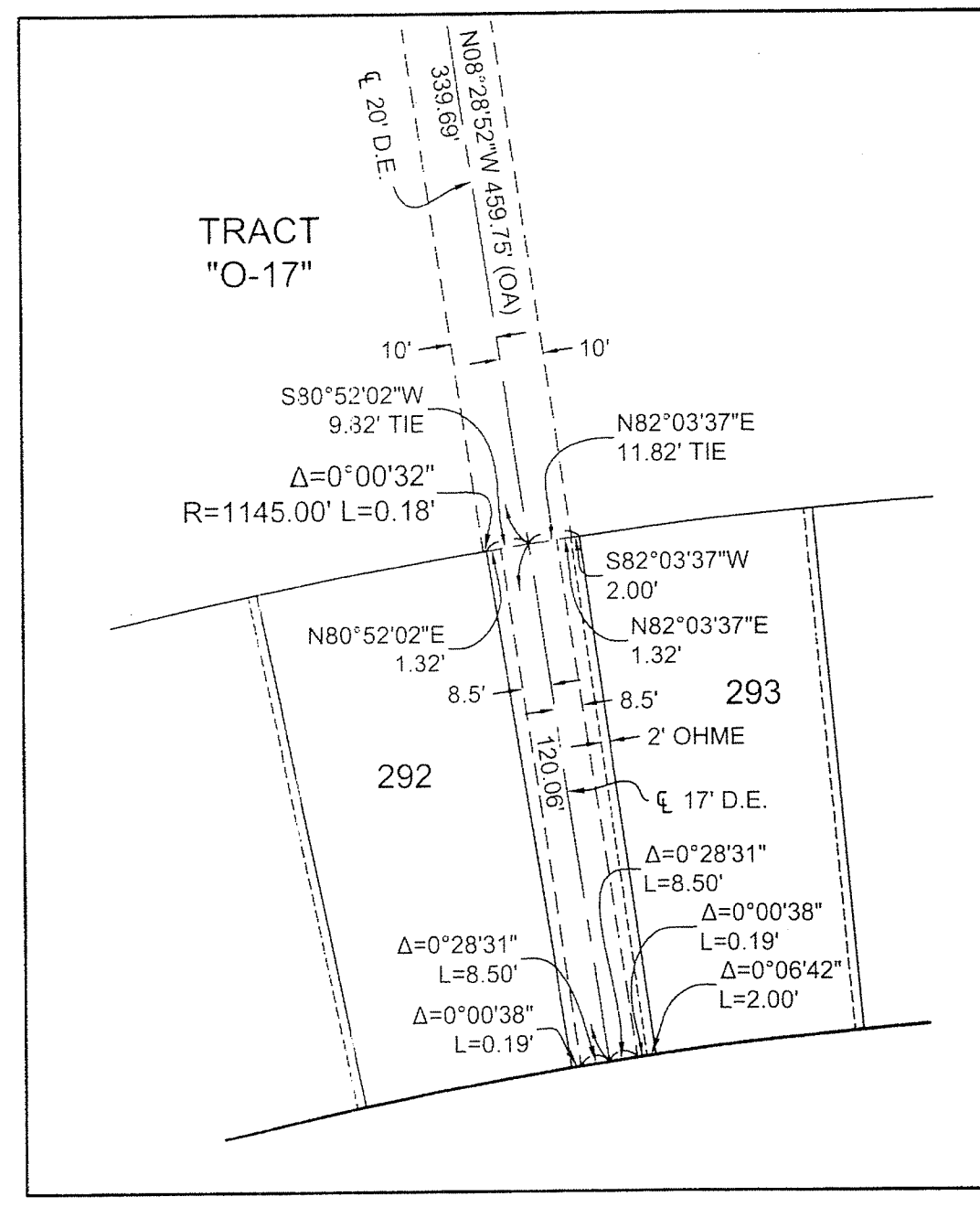

DETAIL "A"
NOT TO SCALE

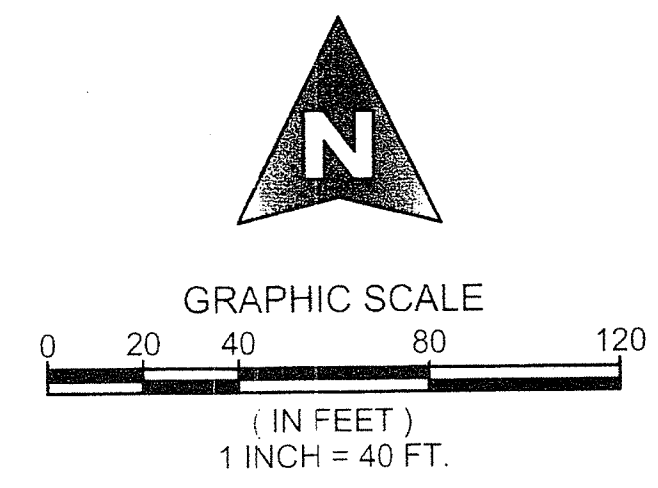
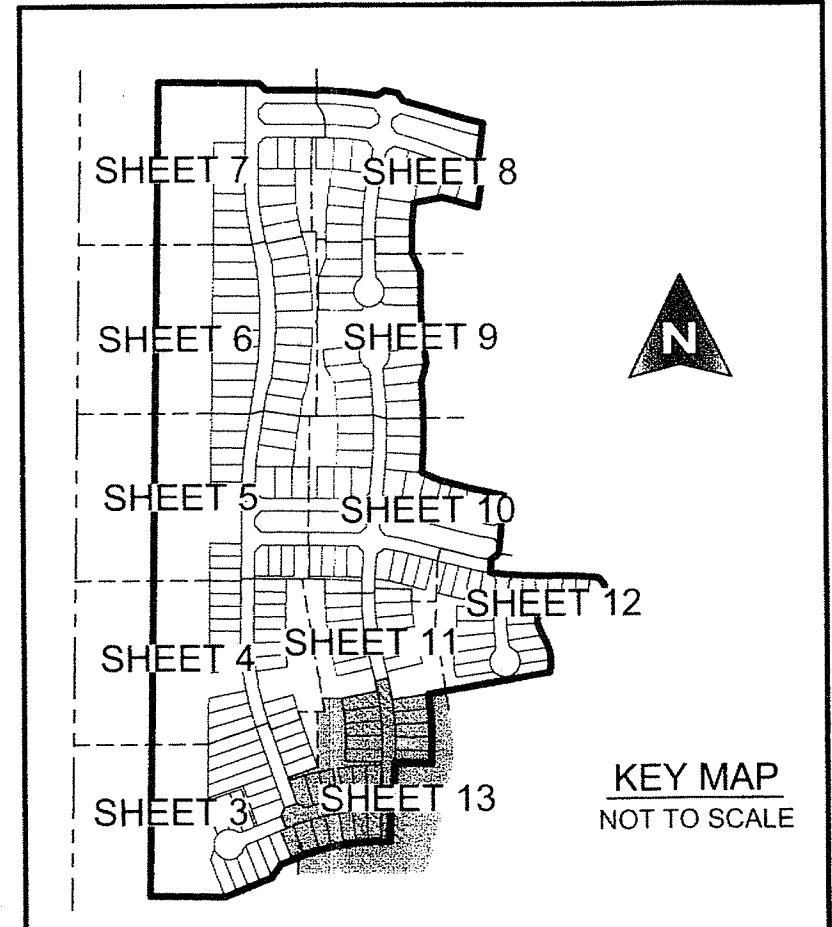
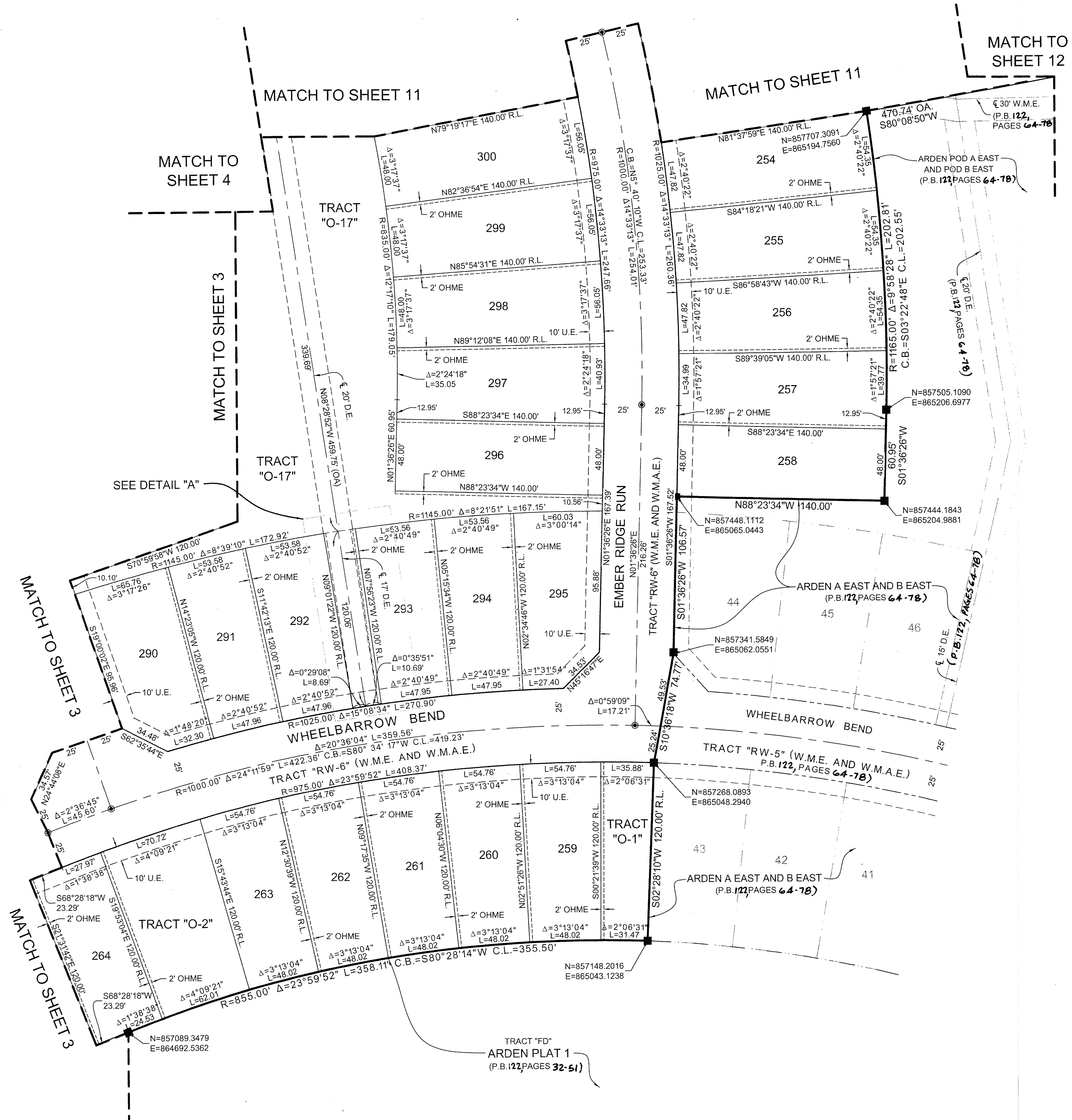

- LEGEND**
- P.O.C. = POINT OF COMMENCEMENT
 - P.O.B. = POINT OF BEGINNING
 - P.C.P. = PERMANENT CONTROL POINT
 - P.R.M. = PERMANENT REFERENCE MONUMENT
 - O.R.B. = OFFICIAL RECORD BOOK
 - P.B. = PLAT BOOK
 - P.G.S. = PAGES
 - D.B. = DEED BOOK
 - P.B.C. = PALM BEACH COUNTY
 - R/W. = RIGHT OF WAY
 - CL. = CENTERLINE
 - U.E. = UTILITY EASEMENT
 - D.E. = DRAINAGE EASEMENT
 - R. = RADIUS
 - L. = ARC LENGTH
 - Δ. = CURVE CENTRAL ANGLE
 - ⊙. = DENOTES FOUND PALM BEACH COUNTY DISK IN CONCRETE
 - ⊙. = SET NAIL AND ALUMINUM DISK, STAMPED P.C.P. L.B. 2438
 - ⊙. = SET 4"x4"x24" C.M. WITH ALUMINUM DISK, STAMPED P.R.M. L.B. 2438
 - ⊙. = DENOTES FOUND P.R.M. (AS SHOWN IF ANY)
 - CL. = CHORD LENGTH
 - C.B. = CHORD BEARING
 - L.M.A.E. = LAKE MAINTENANCE ACCESS EASEMENT
 - R.L. = RADIAL LINE
 - N. = NORTHING, WHEN USED WITH COORDINATES
 - E. = EASTING, WHEN USED WITH COORDINATES
 - L.B.E. = LANDSCAPE BUFFER EASEMENT
 - L.A.E. = LIMITED ACCESS EASEMENT
 - L.S.E. = LIFT STATION EASEMENT
 - FD. = FOUND OVERALL
 - CA. = CONCRETE MONUMENT
 - C.M. = FLORIDA POWER AND LIGHT
 - F.P.L. = LANDSCAPE EASEMENT
 - L.E. = PATHWAY EASEMENT
 - P.E. = PALM BEACH COUNTY UTILITY EASEMENT
 - P.B.C.U.E. = WATER MANAGEMENT EASEMENT
 - W.M.E. = WATER MANAGEMENT ACCESS EASEMENT
 - W.M.A.E. = OVERHANG MAINTENANCE EASEMENT
 - OHME. = PROFESSIONAL SURVEYOR AND MAPPER
 - P.S.M. = NUMBER
 - NO. = PLANNED UNIT DEVELOPMENT

COORDINATES NOTE:
COORDINATES SHOWN ARE GRID
DATUM = NAD 83, 1990 ADJUSTMENT
ZONE = FLORIDA EAST
LINEAR UNITS = US SURVEY FOOT
COORDINATE SYSTEM 1983 STATE PLANE TRANSVERSE MERCATOR PROJECTION
ALL DISTANCES ARE GROUND
PROJECT SCALE FACTOR = 0.99999219
GROUND DISTANCE X SCALE FACTOR = GRID DISTANCE

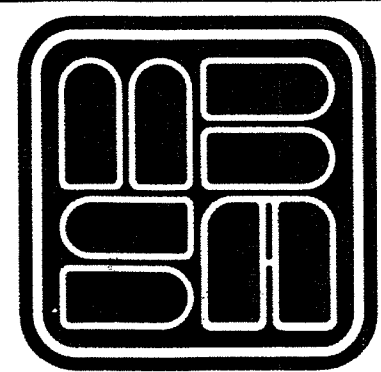

MICHAEL B. SCHORAH & ASSOCIATES, INC.
1860 FOREST HILL BLVD., SUITE 208
WEST PALM BEACH, FLORIDA 33408
EB# 2438 TEL. (561) 968-0080 FAX. (561) 642-9726 LB# 2438

ARDEN P.U.D. POD A WEST AND POD B WEST